

RP SERIES *Thermal Protectors*

WORLD CLASS PERFORMANCE

The RP Series thermal protector is suited for recessed lighting applications. The RP's compact package is designed to mount on the fixture; and, with sensitivity to changes in thermal conditions, detect the presence of insulation.

With a history of more than 95 years, Sensata Technologies is a leading supplier of sensors and switches.

Features

- Wide variety of UL recognized types
- Automatic resetting device
- Device causes fixture light to blink in fault condition
- Sensitivity to thermal conditions
- 50/60 Hz

Benefits

- Capable of accommodating most recessed lighting fixtures
- Compact design allows for easy placement within the lighting fixture

Sensata Technologies' RP Series of thermal protectors are designed to meet UL, CSA and NEC requirements for the protection of non-IC recessed lighting fixtures. This RP thermal protector is an automatic resetting device that causes the lamp to blink during fault conditions. The RP is controlled by Sensata Technologies' SB600 Series of protectors, which are recognized by UL for tungsten and inductive loads (File E28135) and by CSA for inductive loads (File LR20529).

Sensata Technologies is an ISO and TS registered company providing world class quality products.

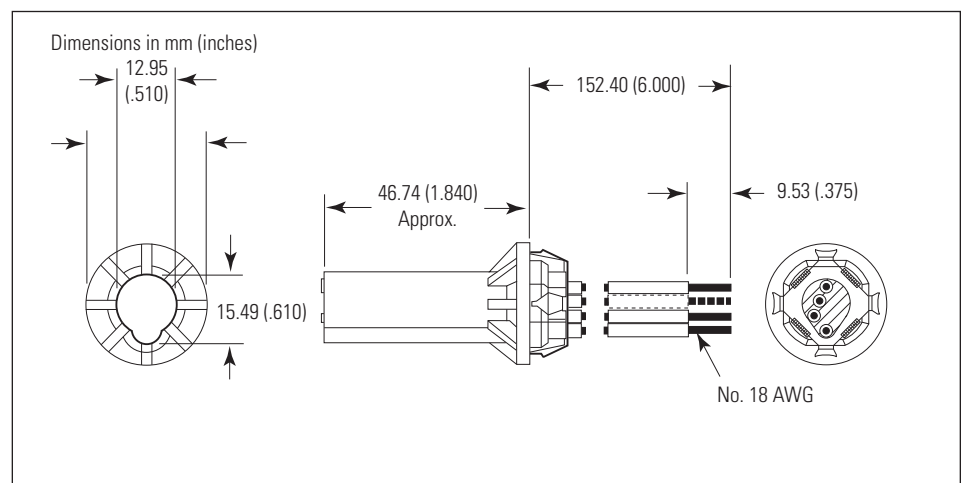

RP SERIES

Thermal Protectors

Electrical and Physical Characteristics

Type	Heater	Sensitivity	No. of Leads	Lead Colors	Heater Wires	Protector Wires	Standard Pack
RP-1B	120V	Low	3	Bk, Wh, Bl	Bl & Wh	Bk & Bl	500
RP-4A	277V	Low	3	Bk, Wh, Red	Red & Wh	Bk & Red	500
RP-5A	120V	Low	4	Bk, Wh, Bl, Red	Red & Wh	Bk & Bl	400
RP-6A	240V	Low	3	Bk, Wh, Grey	Gray & Wh	Bk & Gray	500
RP-7A	208V	Low	4	Bk, Wh, Bl, Yell	Yell & Wh	Bk & Bl	400
RP-8A	120V	Low	3	Bk, Wh, Or	Or & Wh	Bk & Or	500
RP-9A	12V	Low	3	Bk, Wh, Yell	Yell & Wh	Bk & Yell	500
RP-10A	220V	Low	3	Bk, Wh, Viol	Viol & Wh	Bk & Viol	500
RP-11A	120V	High	4	Bk, Wh, Bl, Or	Or & Wh	Bk & Bl	400
RP-12A	277V	High	3	Bk, Wh, Red	Red & Wh	Bk & Red	500
RP-13A	120V	High	3	Bk, Wh, Bl	Bl & Wh	Bk & Bl	500
RP-14A	240V	High	3	Bk, Wh, Grey	Gray & Wh	Bk & Gray	500
RP-15A	208V	High	4	Bk, Wh, Bl, Yell	Yell & Wh	Bk & Bl	400
RP-16A	12V	High	3	Bk, Wh, Yell	Yell & Wh	Bk & Yell	500
RP-17A	220V	High	3	Bk, Wh, Viol	Viol & Wh	Bk & Viol	500
RP-18A	277V	High	4	Bk, Wh, Bl, Or	Or & Wh	Bk & Bl	500

Wiring of RP Thermal Protectors

The following instructions will assist in the proper installation of Sensata's RP Series of thermal protectors.

3 Wire RP for Dedicated Voltage

The black lead wire is always connected to the input live wire. The white wire is the common which is permanently connected at the factory with an extra six inch piece of wire of the same color. The third wire of the RP is permanently connected to the live side of the load.

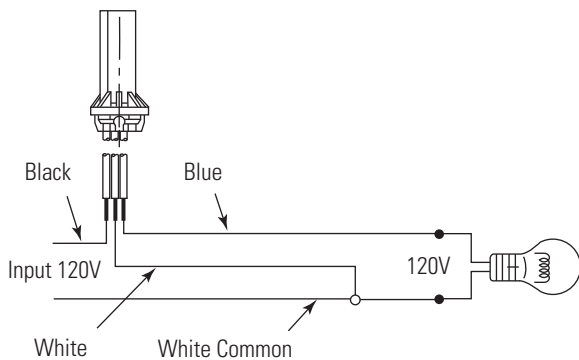

4 Wire RP for Multi-tap Ballasts

The black lead wire is always connected to the input live wire. The white wire is the common which is permanently connected at the factory with all common wires. The red wire of the RP-5A or the orange wire of the RP-11A is connected to the 120 Volt tap of the ballast. The yellow wire of the RP-7A or RP-15A is connected to the 208 Volt tap of the ballast. The orange lead of the RP-18A is connected to the 277 Volt tap. The blue wire is then connected to the tap of the ballast which will match the input voltage. Although the primary usage is 120/277V, the thermal protector inside of these units is rated up to 480 VAC.

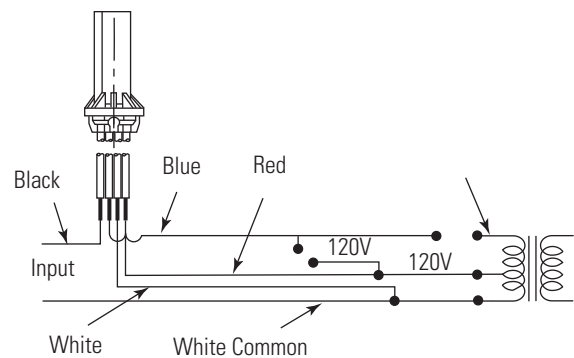

RP SERIES

Thermal Protectors

Applications of RP's to Recessed Fixtures

The following information describes the fixtures' voltage, temperature and RP placement requirements necessary to U.L. normal and abnormal tests. In addition, this information outlines requirements to be met for proper usage of Sensata's RP thermal protectors.

U.L. Normal Test Box

For proper testing of RP's the following conditions should be met:

1. The fixture should be tested at the rated wattage and specified voltage. For example, if the fixture is rated 120 VAC, then the output voltage should be set at 120 VAC. In order for the RP to operate properly, voltage requirements must be adhered to. A higher voltage can, in some instances, derate the RP and cause nuisance tripping.
2. The thru wire temperature, if any, should be adhered to.
3. Maximum temperatures allowed by the standard agencies should not be exceeded.
4. The RP is not dependent on orientation. It can be placed in a vertical position.

U.L. Abnormal Test Box

For proper testing of RP's the following conditions should be met:

1. At least 1 inch of insulation should completely surround the RP.
2. The RP should be located approximately two inches from the bottom of the fixture.
3. Only a small amount of epoxy to hold the thermal-couple should be used on the RP.

Proper Usage

The RP functions as an insulation detector, protecting against insulation. The design of the RP thermal protectors allows a specific model to protect a family of fixtures. The operation of the bimetallic device within the RP functions primarily from the biasing of its internal heater. The heater is matched to the supply voltage and generates the majority of the heat necessary to trip the device if it should be completely surrounded by 1 inch of insulation. In this manner, the RP functions as an insulation detector.

For the best performance, the RP-8A thermal protector is typically used for 300 and 500 quartz lamps and 120 Volt 400 Watt HID fixtures where 90°C thru wire is specified. As an alternative to the lower sensitivity RPs, higher sensitivity RPs are commonly used for low wattage fixtures that are listed by UL for mark spacing.

This drawing represents the typical placement of these devices for maximum performance:

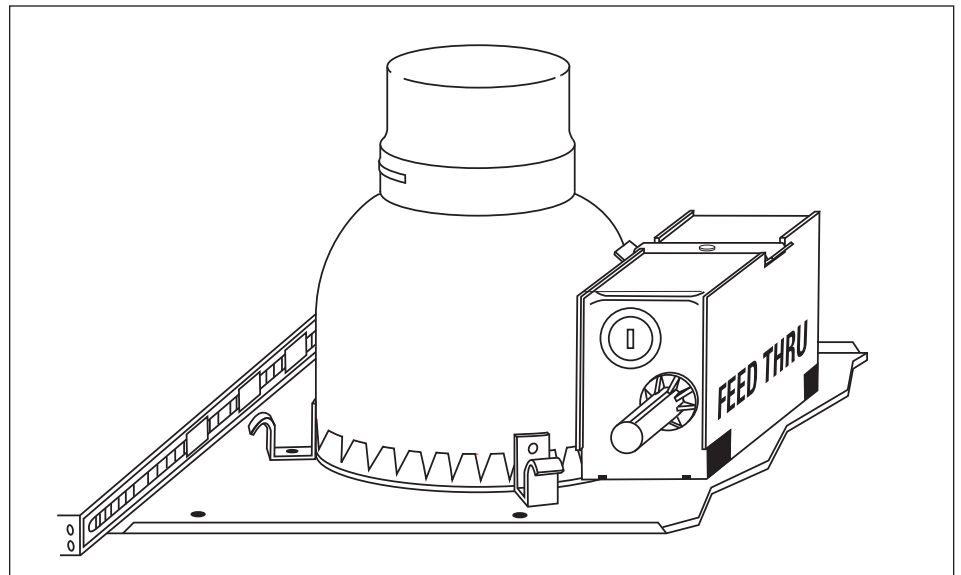

Specifications

The RP and SB600 thermal protector within the RP are recognized and tested under standard UL873 for Temperature Indicating and Regulating Equipment.

The thermal protector within the RP was tested by UL for 10,000 cycles to the following values:

1. 500 Watts at 120VAC with tungsten load.
2. 400 Watts at 120VAC to 480VAC with an inductive load.
3. 75 watts at 12VAC with tungsten load.

The RP has passed tests by UL for the City of Chicago for overlamping in the normal test box and air tightness for the return plenum.

The RP clip is made of spring steel and designed for a 7/8" knockout hole to fit a wall thickness of .032-.078".

RP SERIES

Thermal Protectors

Global Sales Offices

North America

Sensata Technologies, Inc.
Electrical Protection
529 Pleasant Street, MS B-49
Attleboro, Massachusetts 02703
Phone: 1-508-236-3287

Central & South America

Sensata Technologies Sensores e
Controles Do Brasil LTDA.
Rua Azarias de Melo, 648
Bairro Taquaral-Campinas/SP
Brasil
Phone: 19-3754-1142

Europe

Sensata Technologies Holland B.V.
Kolkhofsingel 8
7602 EM Almelo
The Netherlands
Phone: 31-546-879560

Middle East & India

Sensata Technologies India Pvt. Ltd.
Bagmane Tech Park
Byrasandra CV Raman Nagar
Bangalore-560 093
India
Phone: 91-25-099329

Asia

Sensata Technologies (Shanghai) Co., Ltd.
Novel Plaza, 8th Floor
128 Nanjing Road
West Huangpu District
Shanghai 200003, PRC
Phone: 86-21-23061553



Sensata Technologies

529 Pleasant Street
Attleboro, MA 02703-2964
Phone: 1-508-236-3287
Web: www.sensata.com

©2013 Sensata Technologies, Inc. All rights reserved
worldwide. Printed in U.S.A. Revised January 2013.

The World Depends on Sensors and Controls

Important Notice: Sensata Technologies reserves the right to make changes to, or to discontinue, any product or service identified in this publication without notice. Before placing orders, users should obtain the latest version of the relevant information to verify that the information being relied upon is current.

Sensata Technologies assumes no responsibility for customers' product designs or applications. Users must determine the suitability of the Sensata device described in this publication for their application, including the level of reliability required. Many factors beyond Sensata's control can affect the use and performance of a Sensata product in a particular application, including the conditions under which the product is used and the time and environmental conditions in which the product is expected to perform. As these factors are uniquely within the user's knowledge and control, it is essential that the user evaluate the Sensata product to determine whether it is fit for a particular purpose and suitable for the user's application.

Sensata Technologies products are sold subject to Sensata's Terms and Conditions of Sale which can be found at www.sensata.com/terms.htm