

# KLIXON® | 35HM SERIES MOTOR PROTECTORS

*Hermetically Sealed On-Winding, 3-Phase*

## PRODUCT OVERVIEW

The Klixon® 35HM on-winding motor protector is a 3-phase line break, automatic reset device which interrupts line current at the centerpoint of a WYE (Star) wound motor.

Compliant with European Directive 2002/95/EC Restrictions On Use of Hazardous Substances (RoHS)

### Features & Benefits

- Protect WYE (Star) wound 3-phase motors from 4 to 10HP. Used in refrigeration compressors, submersible pumps and other restrictive environments.
- In-line protection in a small, rugged, welded construction. Low profile shape allows for close coupling to motor windings.
- Hermetic reliability designed for leakage rates less than  $1 \times 10^{-9}$ cc per second of air with 1 atmosphere pressure differential.
- Klixon® snap-action discs assure positive make and break action and controlled temperature differential.
- Designed for low and high side pressure applications.

This protector is designed to protect 3-phase refrigeration and air conditioning compressor motors from excessive winding temperature; however, applications may be made to any WYE wound 3-phase motors where environmental conditions require a hermetic seal.

The low profile permits the device to be installed directly on motor windings for closely coupled temperature monitoring, thus enhancing over-temperature protection against loss of refrigeration charge, low voltage locked rotor, and secondary single-phasing (loss of phase).

The 35HM is designed to reduce installation costs by replacing pilot control systems with a simple, economical, compact device.

### Maximum Recommended Locked Rotor Current

Standard Series			
1XX	2XX	3XX	
230V	380V	460V	575V
150A	100A	85A	60A

High Capacity Series			
4XX	5XX	6XX	
230V	380V	460V	575V
240A	175A	145A	100A

Current ratings are based on life test data which has demonstrated high reliability at 5K cycles (standard series) and 2K cycles (high capacity series) at 0.7 power factor on Sensata life test boards.

These capacities are intended as a guide for application work.

*The basic element of the 35HM is the famous Klixon® Snap Acting Disc*

# KLIXON® | 35HM SERIES MOTOR PROTECTORS

*Hermetically Sealed On-Winding, 3-Phase*

## Standard Operating Temperatures

### Opening Temperature

95°C to 175°C (5°C increments)  
Tolerance ±5°C

### Closing Temperature

to suit application  
Tolerance ±9°C

### Pressure Rating

1600 PSIG  
110 bar

## Coding System

When making an inquiry on Klixon® hermetically sealed motor protectors, be certain to specify the entire part number for your application, if known. The six digits following the series identification indicate your specific electrical and physical requirement.

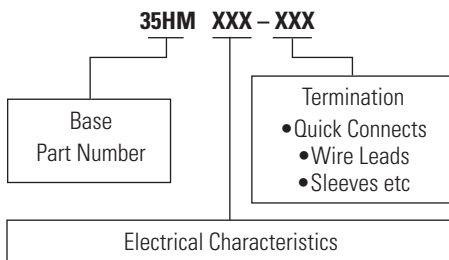

UL & Canadian-UL File # E15692  
CQC File # CQC05002011992  
KEMA (ENEC) File # 2018218.08

## 35HM Hermetic Motor Protector

**Standard / High Capacity Device**

Unit	L	W	H	P1	P2	P2 High Capacity	P3	A	B
Ins	1.470	0.860	1.375	0.735	0.125	0.187	0.250	0.765	1.375
mm	37.3	21.8	34.9	18.7	3.2	4.7	6.4	19.4	34.9

## Electrical Schematic

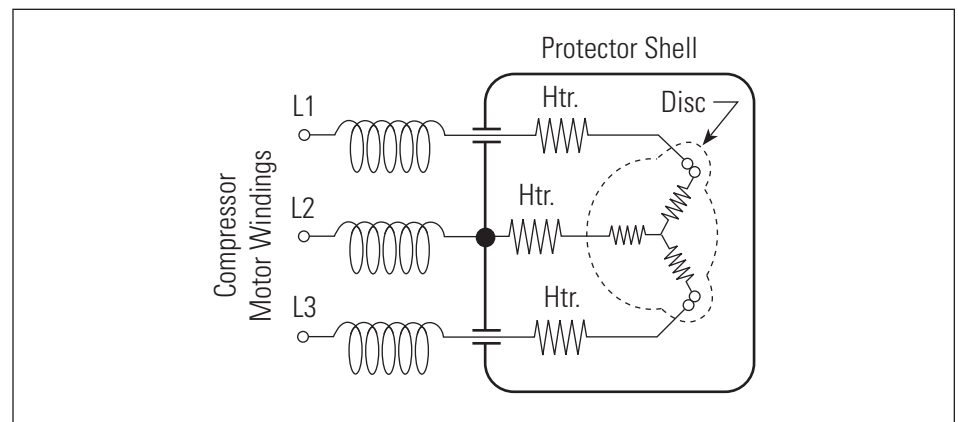

The World Depends on Sensors and Controls

### Sensata Technologies

529 Pleasant Street  
Attleboro, MA 02703-2964  
U.S.A.  
Phone 1-508-236-3800  
www.sensata.com

**Important Notice:** Sensata Technologies (Sensata) reserves the right to make changes to or discontinue any product or service identified in this publication without notice. Sensata advises its customers to obtain the latest version of the relevant information to verify, before placing any orders, that the information being relied upon is current. Sensata assumes no responsibility for infringement of patents or rights of others based on Sensata applications assistance or product specifications since Sensata does not possess full access concerning the use or application of customers' products. Sensata also assumes no responsibility for customers' product designs.